



Leaders in Tribology Test Equipment

Product Brochure

PCS Instruments

A man with glasses and a woman are looking at a computer monitor in a laboratory setting. The man is pointing at the screen. The background shows a wall with posters and a computer monitor.

Developers of world leading fuels & tribology test equipment

3000+ Instruments installed

750+ Technical papers featuring equipment developed by PCS Instruments

100+ Countries using technology from PCS Instruments

35+ Years of operation





Our mission is to develop and supply the most innovative tribology research equipment, to help our customers provide market-leading products and services.







Our commitment to excellence extends beyond the equipment we produce. We work closely with our partners to provide tailored support and guidance, helping our clients overcome complex tribological challenges and optimise performance.

By staying at the cutting edge of tribological advancements, we help companies improve their products and contribute to the development of more efficient and sustainable technologies.

Instrument Index

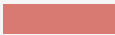
APPLICATION KEY

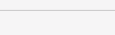
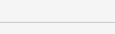
	Fuel Lubricity		Traction, Wear and Tribofilm Activity
	Friction and Wear		Film Thickness
			Rolling Contact Fatigue and Surface Damage

APPLICATION	INSTRUMENT	FEATURE ACCESSORIES	PAGE
	ABS		7
	HFRR		8–9
	HPR		10–11
	MTM	SLIM, EC and CC	12–17
	ETM	SLIM	18–19
	HSD	SLIM and EC	20–21
	EHD	SLIM	22–23
	EHD–HS	SLIM	24–25
	MPR	GI	26–28

Example Applications



LUBRICANTS

- > Developing and optimising lubricant formulations
- > Performance testing of industrial greases
- > Characterising additive performance
- > Validating computational friction and wear models



POWERTRAIN

- > Simulating bearing surface interactions
- > Simulating gear tooth contact behaviour
- > Determining frictional losses within a system and performing efficiency calculations
- > Replicating real-world and extreme contact conditions



GREEN TRIBOLOGY

- > Lubricity testing of new biofuels
- > Developing environmentally acceptable lubricants (EALs)
- > Investigating high-speed traction phenomena in electric vehicles to improve operational efficiency
- > Recreating and analysing failure modes in wind power transmission systems



INDUSTRIAL

- > Developing and optimising metal working fluid formulations
- > Analysing the interactions between seals and moving components
- > Designing advanced coatings to protect surfaces during operation



TRANSPORT

- > Lubricity testing of sustainable aviation fuels
- > Evaluating marine greases and lubricants
- > Developing specialist greases for the rail industry
- > Characterising atmospheric effects on friction and wear



AUTOMOTIVE

- > Lubricity testing of diesel fuels and gasolines
- > Simulating transmission interactions
 - e.g. piston rings, cams, engine bearings
- > Characterising friction materials for clutch pads



BIOMEDICAL

- > Predicting the performance of replacement hip joints
- > Developing comfortable and functional prosthetics
- > Studying the tribological performance of different medical devices



LIFESTYLE

- > Characterising the spreadability of skin creams and other cosmetics
- > Designing more effective haptic feedback systems
- > Optimising the performance of sporting goods and consumables



FOOD & BEVERAGE

- > Analysing food oral processing phenomena
- > Quantifying mouthfeel properties like astringency and creaminess
- > Developing healthier foods using alternative proteins and reduced fat/sugar ingredients



FUELS

- > Standardised lubricity testing of diesel fuels and gasolines
- > Standardised lubricity testing of aviation turbine fuels
- > Validating the performance of sustainable aviation fuels
- > Developing new biofuels



Client Testimonials



CHIEF SCIENTIST & TRIBOLOGIST

We use test data from our PCS machines to develop high-performance cost-effective products. I prefer PCS machines for my Tribological work. I really appreciate the exceptional customer service that we receive from PCS on instruments, specimens, and maintenance.



LECTURER IN MEDICAL ENGINEERING

PCS have been supportive throughout our research and are on hand to answer any queries about how best to optimise our use of their equipment. It is highly beneficial when conducting work in biological soft tissues which come with natural variations to have a trusted company to liaise with.

PROJECT LEADER

We will keep using PCS machines because PCS equipment is becoming the industry standard, i.e., OEMs specifically ask lubricant suppliers to get data by using PCS equipment.



RESEARCH ASSOCIATE

Over the years, PCS machines have enabled and helped me to evaluate the performance of lubricants and their additives, develop standard test methods for the industry, solve problems faced by the industry, and initiate fundamental scientific research in different aspects.

ABS



OVERVIEW

A fully automated, Ball-on-Cylinder Lubricity Evaluator (BOCLE) system which provides a fast, repeatable assessment of the lubricity of aviation fuels.

PCS Instruments is a named supplier of the ABS in the ASTM D5001 standard test method - Standard Test Method for Measurement of Lubricity of Aviation Turbine Fuels by the Ball-on-Cylinder Lubricity Evaluator (BOCLE).

FEATURES & BENEFITS

- > Simple to use interface - microprocessor control of all instrument functions.
- > Standard ASTM D5001 test sequence pre-loaded into ABS microprocessor controller.
- > Optional PC-based data logging software allows test data to be recorded as a permanent record.



TEST PROCEDURE

1. A half-inch diameter steel ball is loaded against a rotating steel cylinder that is partially immersed in a fuel reservoir. The reservoir holds 50 ml of test fuel and is maintained at 25 °C under a controlled airflow at 10 % relative humidity.
2. A 1 kg load is applied to the ball, and then the test cylinder is rotated at 240 rpm.
3. After a conditioning and 30-minute test, the wear scar on the ball is measured. The average wear scar diameter (WSD) indicates the fuel's lubricating performance.

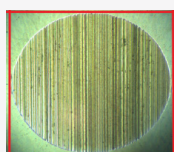

Wear scar after an ABS test (wear scar limits denoted by the red bands)

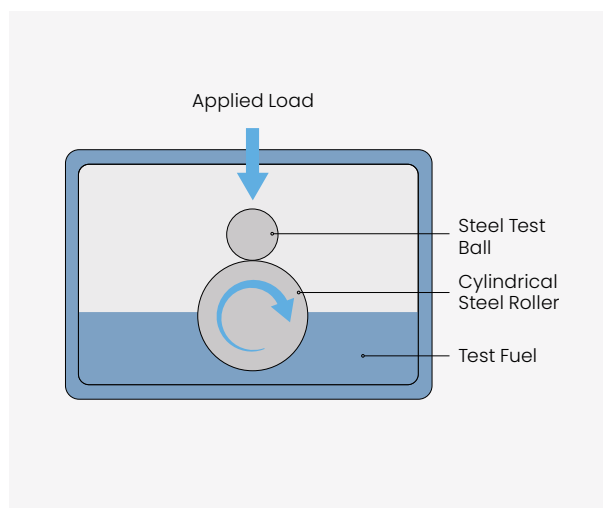

HFRR



OVERVIEW

A ball-on-plate reciprocating friction and wear test system for assessing the performance of both fuels and lubricants under boundary conditions.

PCS Instruments is the only specified supplier of the HFRR in the following standard test methods:

ISO 12156

Diesel fuel – Assessment of lubricity using the high-frequency reciprocating rig (HFRR).

ASTM D6079

Standard Test Method for Evaluating Lubricity of Diesel Fuels by the High-Frequency Reciprocating Rig (HFRR).

ASTM D7688

Standard Test Method for Evaluating Lubricity of Diesel Fuels by the High-Frequency Reciprocating Rig (HFRR) by Visual Observation.

+ Conforms to **CECF-06-A**, **EN 590**, **JPI-5S-50** and **IP 450**.

APPLICATIONS

- > Evaluating the lubricity of diesel fuels and gasolines.
- > Characterising the performance of boundary lubrication additives – E.g. antiwear additives, extreme pressure additives and friction modifiers.
- > Evaluating marine engine lubricants.
- > Studying fretting phenomena.

PRINCIPLE

1. The ball and plate specimens are fitted to the upper and lower sample holders, which are then secured to the instrument.
2. The test sample is added, and a load is applied using a suspended weight.
3. Test parameters are configured via the PC software, either automatically for standard tests or by the user for custom tests.

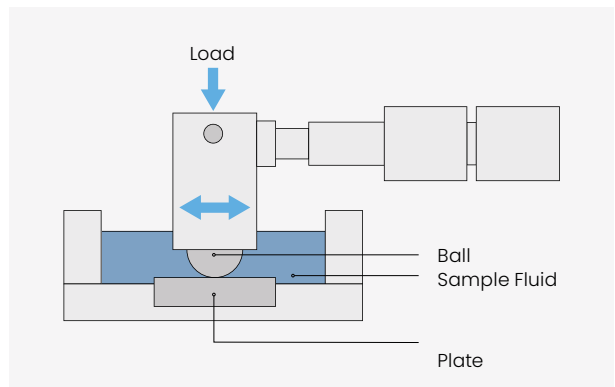

Captured using the optional HFRR microscope and wear scar camera

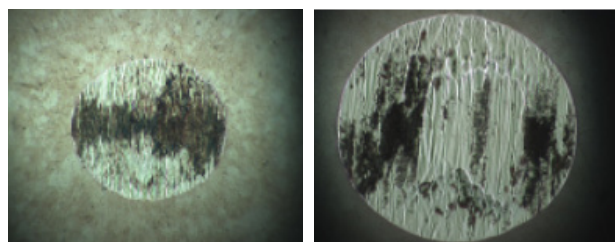

High lubricity wear scar

Low lubricity wear scar

OPERATING CONDITIONS

Frequency	10 to 200 Hz
Stroke length	20 µm to 2 mm
Load	0.1 to 1 kg
Contact pressure	Up to 1.4 GPa
Test sample volume	2 ml
Temperature range	Ambient to 150 °C

ENVIRONMENTAL CONTROL

Chamber Temperature	20 to 26 °C
Chamber Humidity	25 – 75 %RH

The ISO 12156 standard specifies a humidity range of 48 to 58 %RH. The environmental chamber can control humidity to within ± 1% of a 53 %RH target.

FEATURES & BENEFITS

- > **Active Environmental Conditioning:**
Ensures precise control of temperature and humidity.
- > **Intuitive Touchscreen Interface:**
Features an easy-to-use, integrated display for seamless operation.
- > **Configurable Workflows:**
Customisable test reports and automation options for simplified LIMS integration.
- > **Configurable User Profiles:**
Enhances testing and calibration traceability with easy profile setup.

EXAMPLE RESULTS

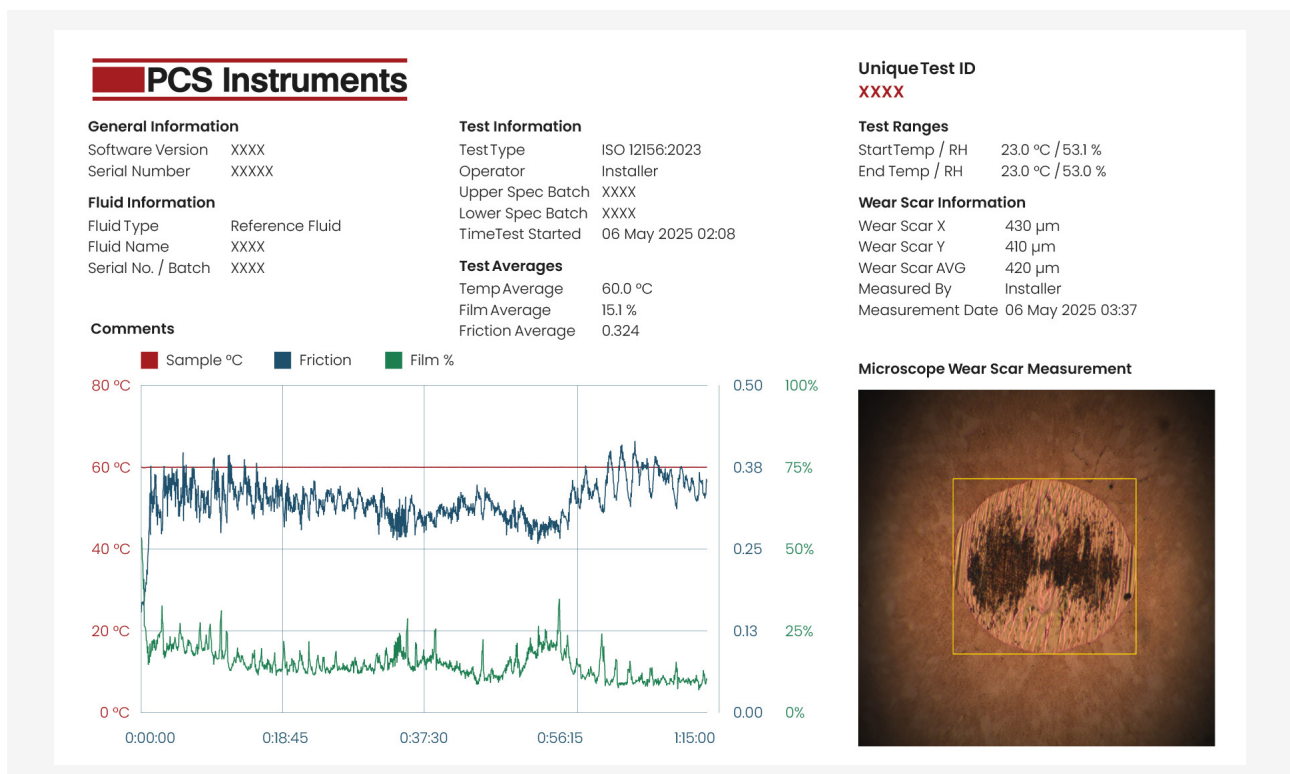

Example Test Report

HPR



OVERVIEW

A ball-on-plate system for studying tribological contacts under a variety of controlled conditions, including:

- [1] Gaseous settings
- [2] Vacuum environments
- [3] Pressurised atmospheres

FEATURES & BENEFITS

- > Gas blends can be added to the chamber whilst removed from the instrument.
- > Multiple chamber configurations allow for dry contacts, liquid lubricants and gases to be tested.
- > Low-cost, standardised specimens improve reliability and repeatability of tests.
- > Small sample volumes of test gases and liquids minimise operating costs and reduce wastage.

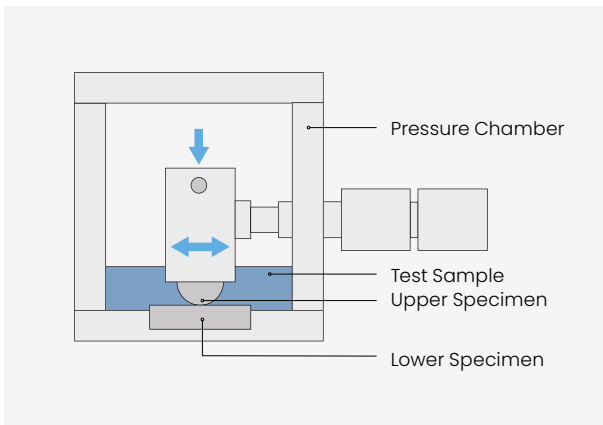
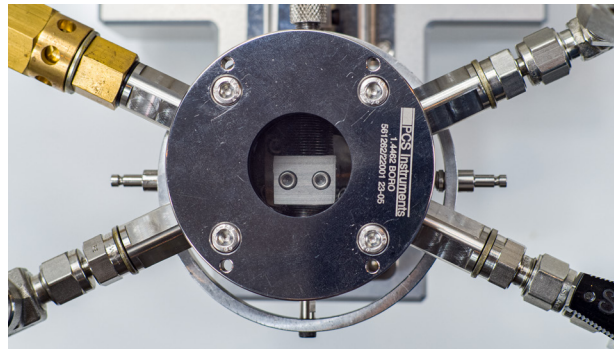

OPERATING CONDITIONS

Frequency	10 to 200 Hz
Stroke length	20 μm to 1.8 mm
Load	0.1 to 1 kg
Contact pressure	Up to 1.4 GPa
Test sample volume	15 ml

ENVIRONMENTAL CONTROL

Temperature range	Ambient to 130 $^{\circ}\text{C}$
Pressure range	$< 10^{-3}$ to 10 bar
Gas chamber volume	60 ml

EXAMPLE RESULTS

Changes in friction response of isooctane when switching between dry air to [1] propane and [2] hydrogen atmospheres.

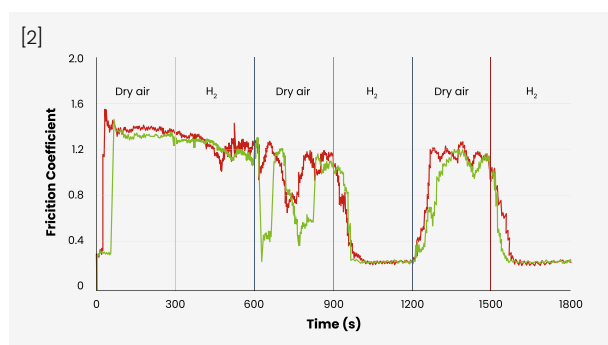
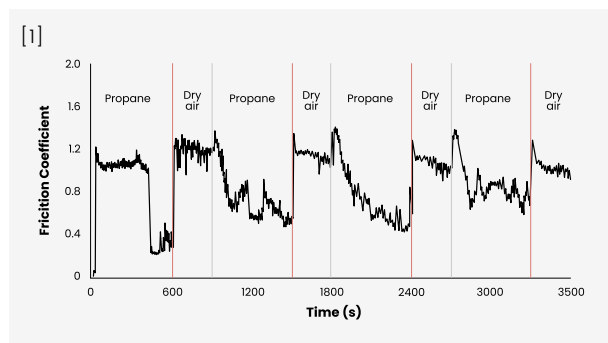

Results courtesy of Prof. Hugh Spikes and Dr. Janet Wong, Imperial College London

Full paper: Zhang, J., Bolle, B., Wong, J.S.S. et al. Influence of Atmosphere on Carbonaceous Film Formation in Rubbing, Metallic Contacts. Tribol Lett 72, 4 (2024). <https://doi.org/10.1007/s11249-023-01801-9>

APPLICATIONS

- > Evaluating the lubricity of volatile fuels and fuel blends.
- > Studying the behaviours of lubricants in controlled atmospheres – e.g. Hydrogen, Ammonia, Argon.
- > Evaluating the behaviours of refrigerants at high pressures.
- > Studying fretting in gaseous environments.
- > Investigating the effects of hydrogen embrittlement in tribological systems.
- > Formulating gas blends with gaseous additives to enhance lubricity.
- > Characterising the performance of surface coatings in vacuum, gaseous and/or pressurised environments.

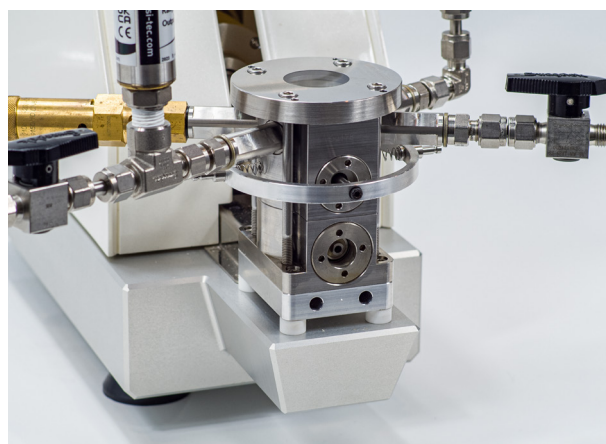
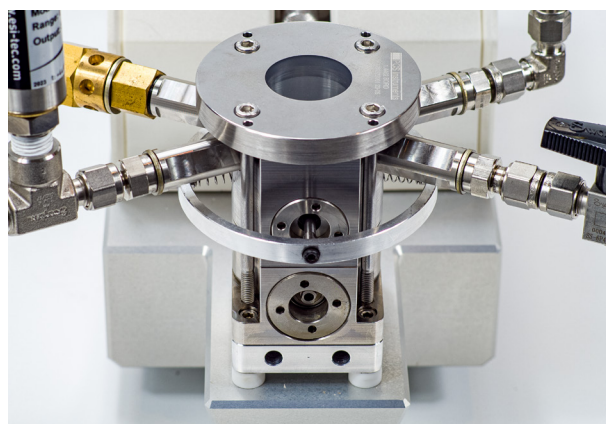

Ports include:

- > Gas inlet valve + Digital pressure sensor
- > Burst valve
- > Pressure relief valve
- > Gas outlet valve



OVERVIEW

A ball-on-disc instrument for measuring the frictional properties of lubricated and unlubricated contacts across a wide range of rolling and sliding conditions.

FEATURES & BENEFITS

- > Cited in more than 500 publications.
- > Proven instrument with over 300 units installed worldwide.
- > Independently driven specimens enable a wide range of contact conditions to be replicated across all three lubrication regimes, including boundary, mixed and EHL.
- > Highly repeatable and accurate.

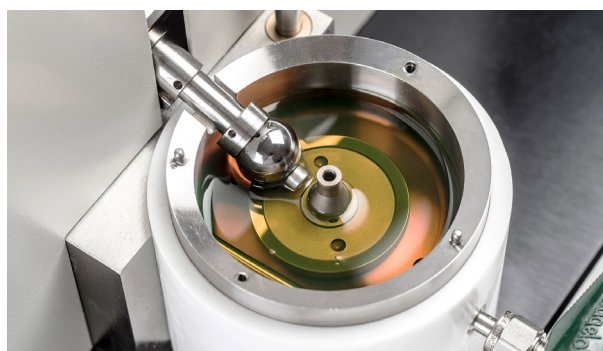

OPERATING PARAMETERS

Load*	10 to 75 N
Contact Pressures*	Up to 1.25 GPa
Speed	Up to +/- 4 m/s
Slide / Roll Ratio	0 to +/- 10,000 %
Temperature Range*	Ambient to 150 °C
Test Sample Volume*	35 ml

* Expanded functionality possible with relevant accessories and / or specimens.



APPLICATIONS

- > Developing and optimising lubricant formulations.
- > Performance testing of industrial greases.
- > Characterising the functionality of lubricant additives.
- > Evaluating metalworking fluid formulations.
- > Improving the sensory perception and texture of food and beverage products.
- > Assessing the skin feel of cosmetic products.

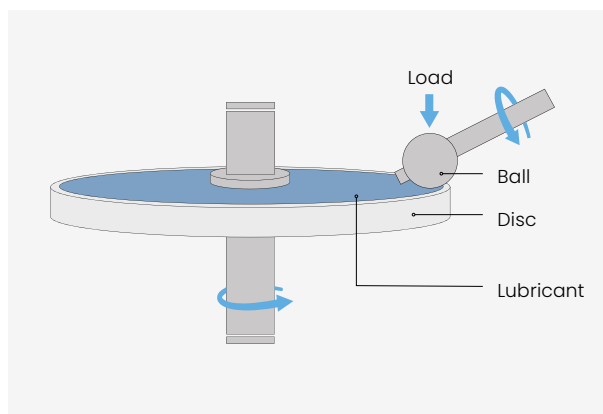

EXAMPLE RESULTS

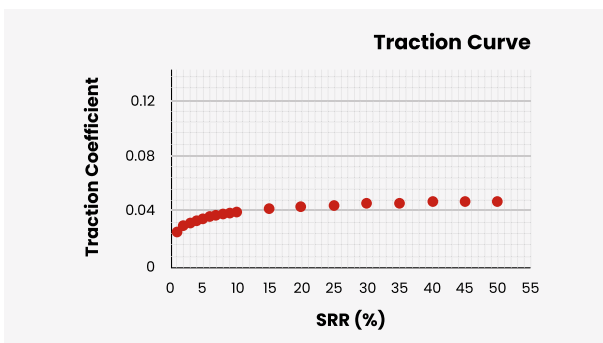
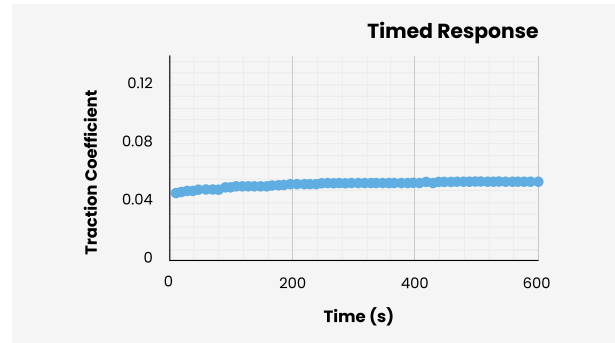
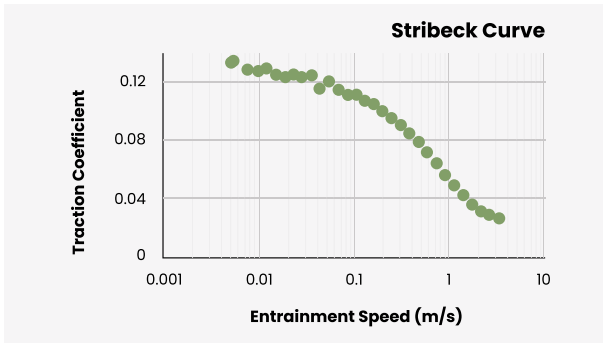

ACCESSORIES



Cooler

Rapidly cools down the test cell for quicker repeat testing and below ambient temperatures



Reciprocating option

Changes the motion of the disc to a reciprocating cycle



Grease scoop

Delivers grease to the contact



Grease applicator

Evenly applies grease at 12 points around the disc



Pot filler

Reduces test sample volumes to less than 10 ml

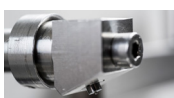

Pin-on-disc option

Locks the upper specimen to prevent any rotation



ECR option

Indicates the amount of surface contact during testing



Low load kit

For applying loads between 2 N to 8 N



Glass lid

Allows users to observe the contact during testing



Mini pot

Supports 3rd body particles and reduced volume testing



O-ring holder

Allows the ball to be replaced by an o-ring

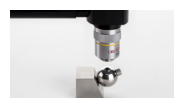

Specimen holder

Precisely angles ball specimens for easy microscopy analysis

MTM-SLIM



OVERVIEW

The Spacer Layer Imaging Method (SLIM) accurately and automatically measures additive-induced tribofilm formation during a test, enabling direct comparisons to be drawn between different additive packages.

PRINCIPLE

1. The upper specimen is loaded against the disc and run under preset conditions for a fixed duration.
2. Periodically throughout the test, the ball is stopped, reverse-loaded against a glass window and an interferometric image of the complete contact area is captured.
3. Tribofilm thickness maps can then be constructed for each image.

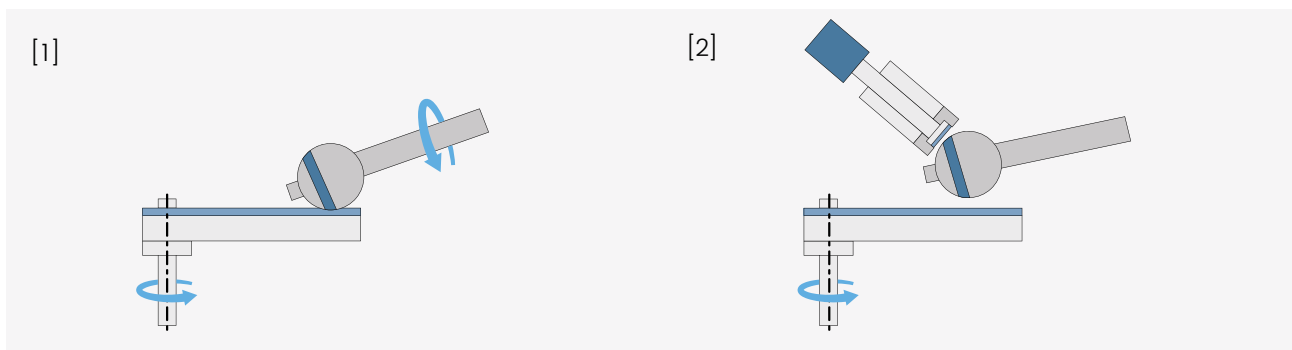

EXAMPLE RESULTS

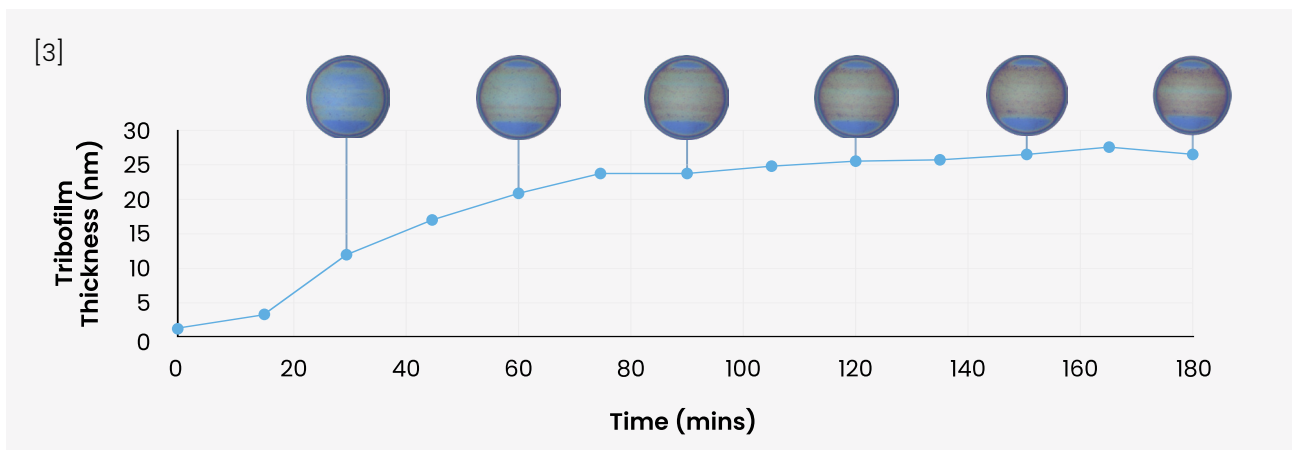

MTM-CC



OVERVIEW

An accessory to the MTM2 and MTM-EC that enables MTM testing to be performed in alternative gas environments at ambient pressures.

COMPATIBILITY WITH EXISTING ACCESSORIES

Accessory	Compatible	Notes
SLIM	✓	When used with the MTM-CC SLIM Mapper Kit
EC System	✓	
Cooler	✓	
Low Load Option	✓	
Reciprocating Option	✓	
ECR	✓	
Pot Filler	✓	
Grease Scoop	—	Alternative grease scoop kit available
Pin-on-Disc Kit	✗	

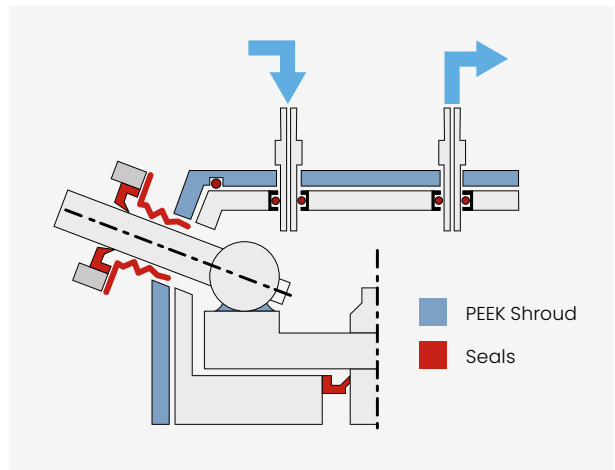
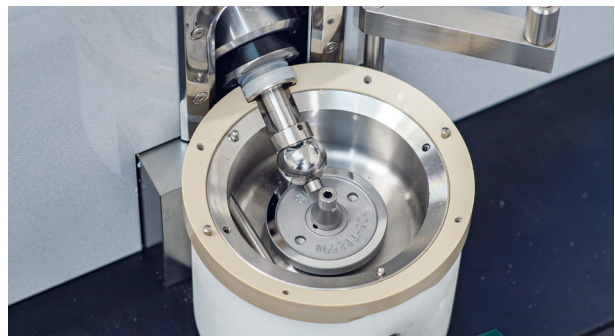

FEATURES & BENEFITS

- > Standard-sized inlet and outlet ports enable a controlled gas flow through the MTM's pot.
- > High-performance Kalrez® and fluorosilicone seals ensure optimal compatibility with a wide range of gases.
- > A highly flexible ball shaft seal provides effective gas isolation without effecting traction measurements.

APPLICATIONS

- > Assessing lubricant performance under controlled environmental conditions.
- > Measuring friction and wear in inert and reactive atmospheres.
- > Studying the impact of controlled atmospheric conditions on the development of boundary additive films.

MTM-EC



OVERVIEW

The MTM-EC is an upgrade for existing MTM2 systems that allows users to apply an electrical potential across the ball-on-disc contact.

EC SCHEMATIC

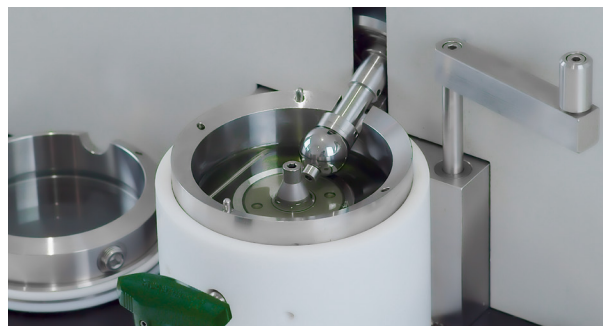
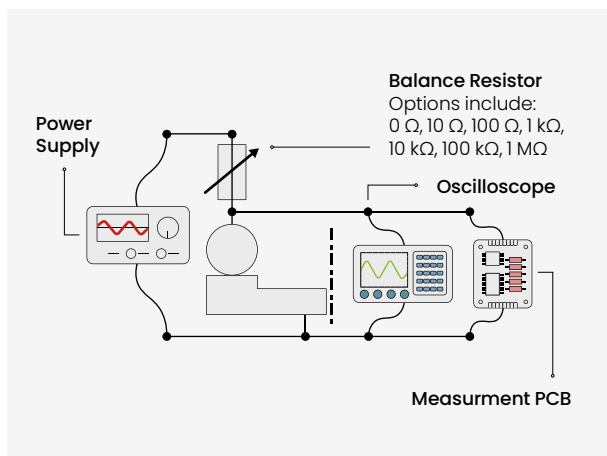

EC OPTIONS

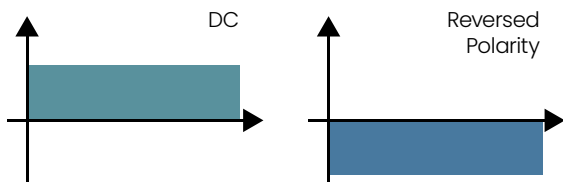

AC possible with optional waveform generator

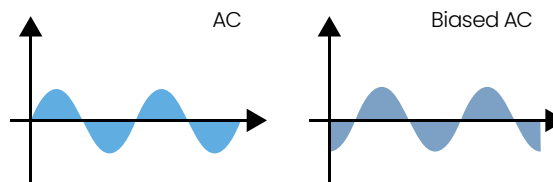

+ Sine, square, triangular, sawtooth and other custom waveforms

EC PARAMETERS

Data Acquisition Voltage and current channels sampled at up to 80 M samples per second

AC		Low Range		High Range	
	Voltage (Pk/Pk)	0 to 20 V	± 20 mV	0 to 29 V	± 120 mV
	Current (Pk/Pk)	0 to 400 mA	± 0.4 mA	0 to 580 mA	± 20 mA
	Frequency Range	0.03 Hz to 500 kHz			
DC		Low Range		High Range	
	Voltage	0 to 10 V	± 20 mV	0 to 35 V	± 120 mV
	Current	0 to 200 mA	± 0.4 mA	0 to 2 A	± 20 mA

EXAMPLE RESULTS

Square wave applied across the contact with corresponding current response. Occasional film breakdown is indicated by a rise in current and drop in voltage.

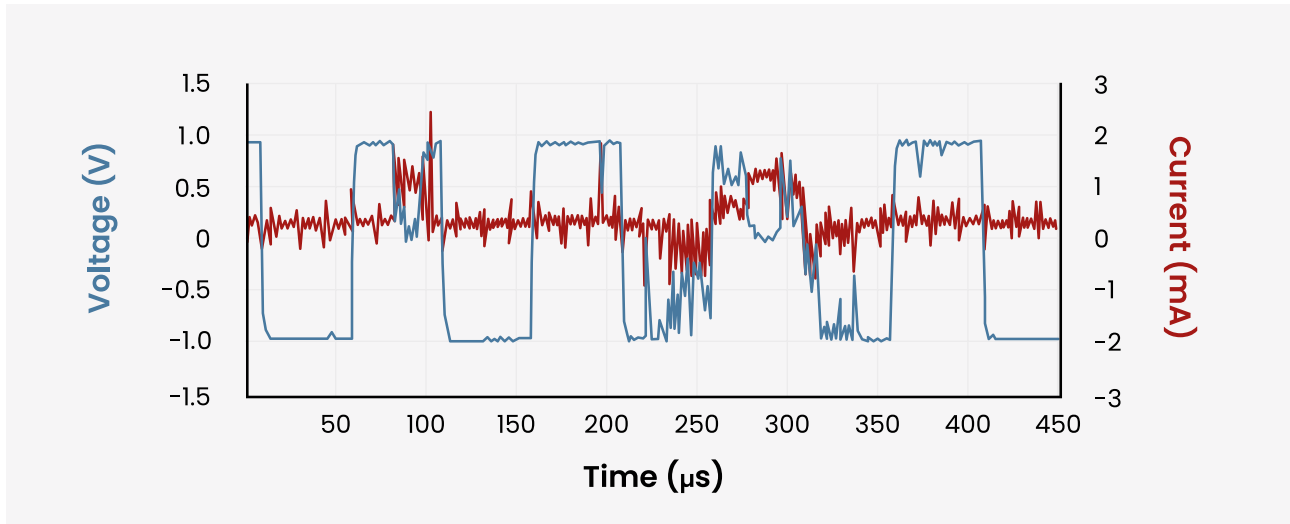

ELECTRIC POTENTIALS HAVE BEEN SHOWN TO AFFECT:

- > Traction
- > Wear and Surface Roughness
- > Tribofilm Formation

Indication of damage to the ball [1] and disc [2] from electrical discharges across contact.

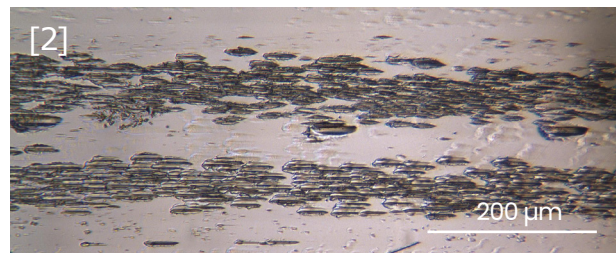
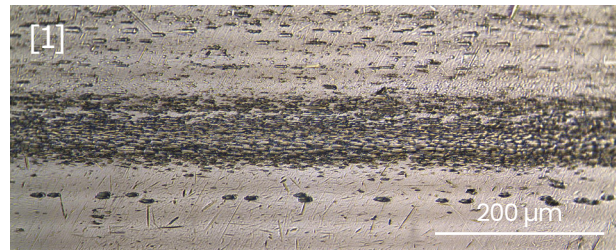

FEATURES & BENEFITS

- > Polarity is reversible, allowing either the ball or disc to be made live during testing.
- > Voltages and currents can be easily selected and automatically controlled via the MTM-EC software.
- > With sampling rates of up to 80 million samples per second, individual discharge events can be accurately captured.
- > The EC system also supports the use of an external oscilloscope and power supply.

APPLICATIONS

- > Lubricant development for electric vehicle transmissions.
- > Performance testing of gear oils and bearing greases for wind turbines.
- > Characterising additive responses to electric fields.
- > Studying triboelectric effects.

ETM



OVERVIEW

A high-load ball-on-disc instrument for measuring the frictional properties of lubricated and unlubricated contacts under extreme pressures across a wide range of rolling and sliding conditions.

APPLICATIONS

- > Measuring the formation and removal of anti-wear tribofilms at high contact pressures.
- > Studying the effect of very high shear stresses on lubricant/material chemistry (mechanochemistry).
- > Determining the scuffing resistance of lubricants.
- > Characterising lubricant properties for traction drive applications.
- > Exploring the behaviour of friction modifiers at realistic contact pressures.

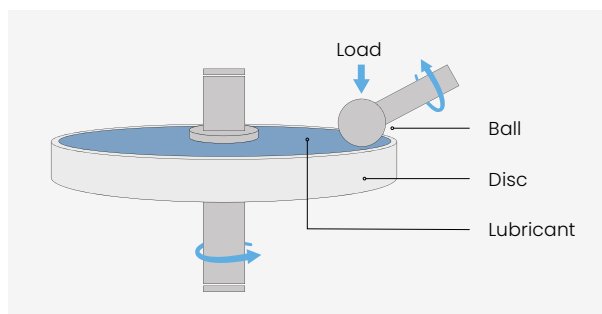

OPERATING PARAMETERS

Load	100 to 1650 N
Contact Pressures*	1.4 to 3.5 GPa
Speed	Up to +/- 3.5 m/s
Slide / Roll Ratio	0 to +/- 10,000 %
Temperature Range*	Ambient to 150 °C
Test Sample Volume	30 ml

* Expanded functionality possible with relevant accessories and / or specimens.

SLIM COMPATIBLE

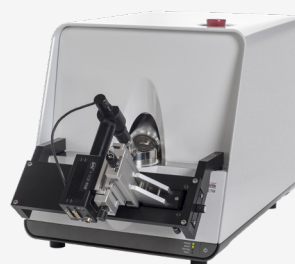

* The ETM can be equipped with the SLIM as an optional accessory

CONTACT PRESSURE COMPARISONS

Standard AISI 52100 Steel Specimens

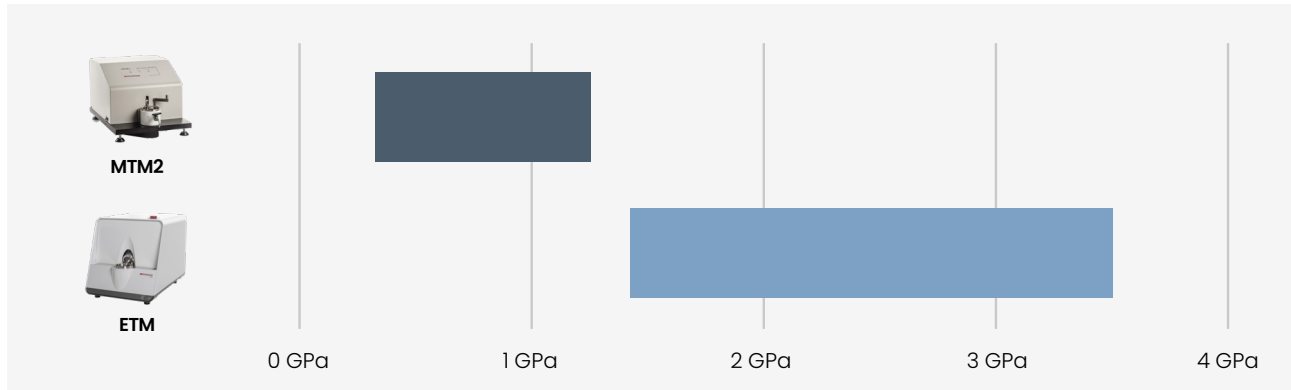

EXAMPLE RESULTS

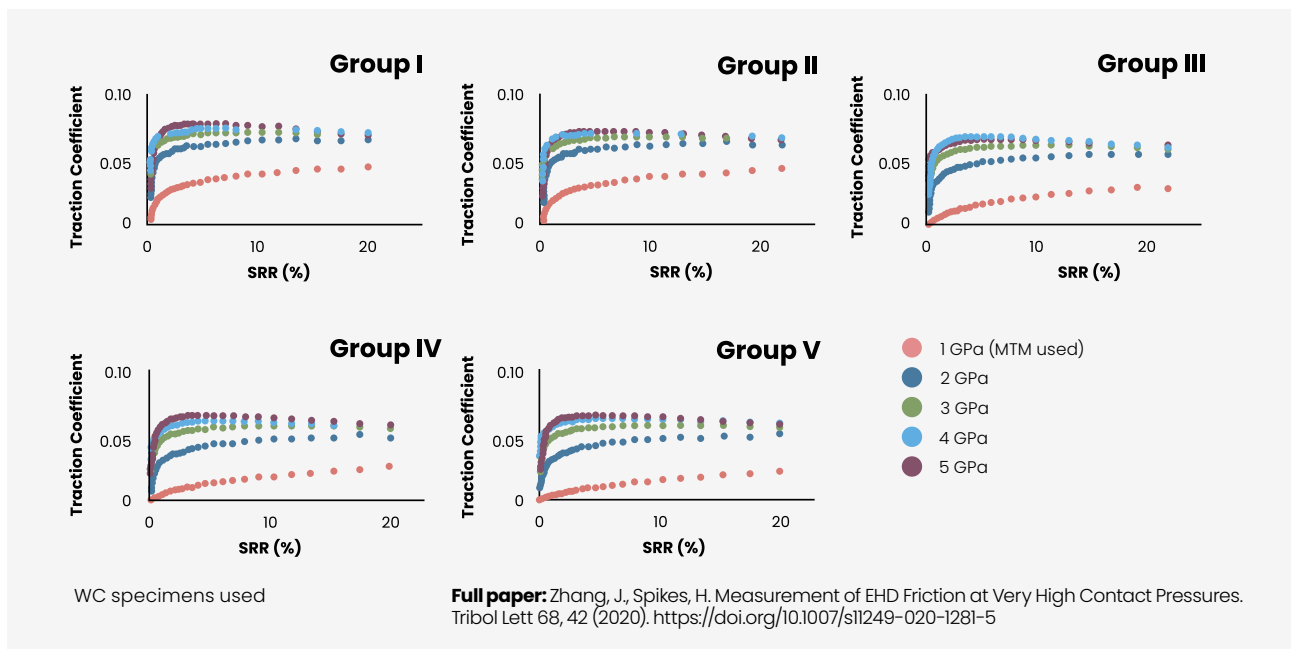

FEATURES & BENEFITS

- > Contact pressures and areas similar to those found in real-world applications can be replicated.
- > All lubrication regimes can be achieved (boundary, mixed, EHL) under maximum contact pressures.
- > Optional accessories, including the grease scoop and applicator, support grease-focused research.
- > Independently driven ball and disc motors allow for both co- and contra-rotation motions.
- > The ETM is supplied with a Fluid Extraction System (FES) which automatically drains a sample after testing, enabling quicker test turnarounds.

HSD



OVERVIEW

The HSD is a twin-disc tribometer designed to measure friction in non-conformal contacts at surface speeds up to 62.5 m/s.

APPLICATIONS

- > Evaluating lubricants for EV transmissions, turbines, and high-speed spindles.
- > Conducting fundamental research into high-shear effects on friction and tribofilm growth.
- > Validating thermal elastohydrodynamic lubrication (EHL) models.
- > Testing alternative lubricants such as emulsions and water-based fluids.
- > Studying starvation, lubricant delivery, and foaming in high-speed contacts.

SLIM COMPATIBLE



EC COMPATIBLE



EC parameters are identical to those of the MTM-EC, as detailed on page 18.

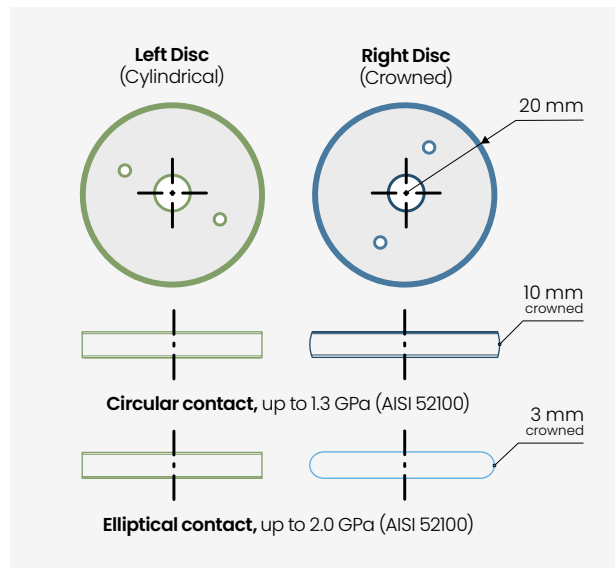

ENTRAINMENT SPEED COMPARISONS

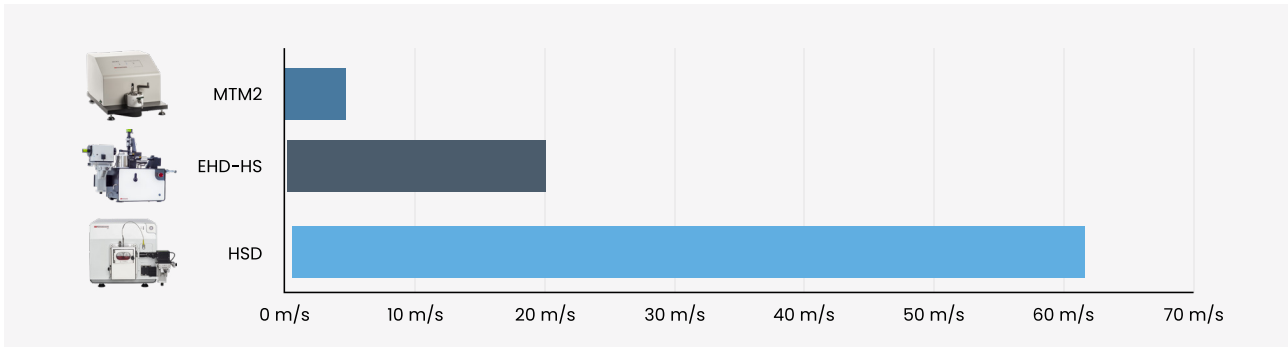

EXAMPLE RESULTS

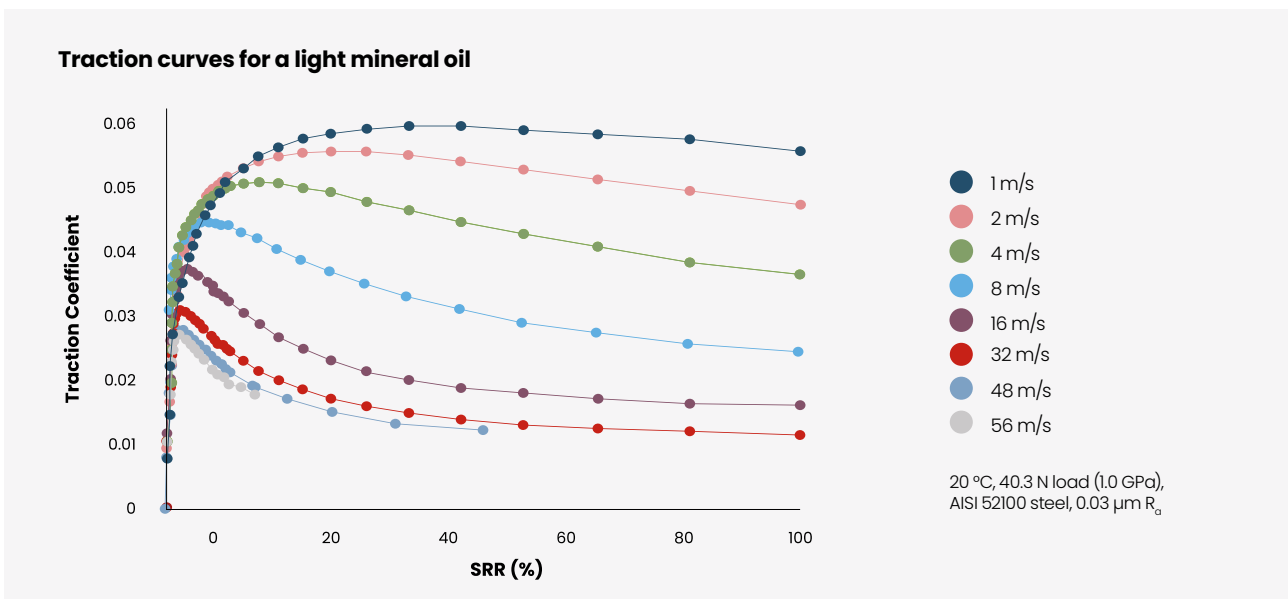

OPERATING PARAMETERS

Load	10 to 90 N
Contact Pressures*	Up to 1.3 GPa
Speed	0.5 to 62.5 m/s
Slide / Roll Ratio	0 to +/- 10,000 %
Temperature Range*	Ambient to 150 °C
Test Sample Volume	30 ml

* Expanded functionality possible with relevant accessories and / or specimens.

FEATURES & BENEFITS

- > Traction measurement using a calibrated load cell with mN precision.
- > HSD contacts are directly comparable to those achieved in the MTM, so existing datasets can be extended to include higher speed results.
- > Real-time monitoring of vibration.
- > Independently driven discs allow full control over slide roll ratio.
- > Fully automated operation via the HSD-PC software.



OVERVIEW

A fully automated, benchtop instrument, measuring lubricant film thickness down to 1 nm in the elastohydrodynamic (EHD) lubricating regime.

APPLICATIONS

- > Evaluating the film-forming properties of oils and greases.
- > Characterising starvation and reflow behaviour in grease lubricated components.
- > Testing alternative lubricants such as emulsions and water-based fluids.
- > Evaluating the dispersion, stability and morphology of nanoparticle additives.

OPERATING PARAMETERS

Film Thickness	1 to 1000 nm
Load	2 to 50 N
Contact Pressures*	Up to 2.0 GPa
Speed	1 mm/s to 4 m/s
Slide / Roll Ratio	0 to +/- 200 %
Temperature Range*	Ambient to 150 °C
Test Sample Volume	120 ml

* Expanded functionality possible with relevant accessories and / or specimens.



FEATURES & BENEFITS

- > The optical interferometry technique allows for precise measurements down to 1 nm, well beyond the capabilities of most other methods.
- > Contact pressures and shear rates comparable to those found in gears, rolling element bearings and cams, can be achieved.
- > Fully automated, easy to calibrate, and has intuitive software.

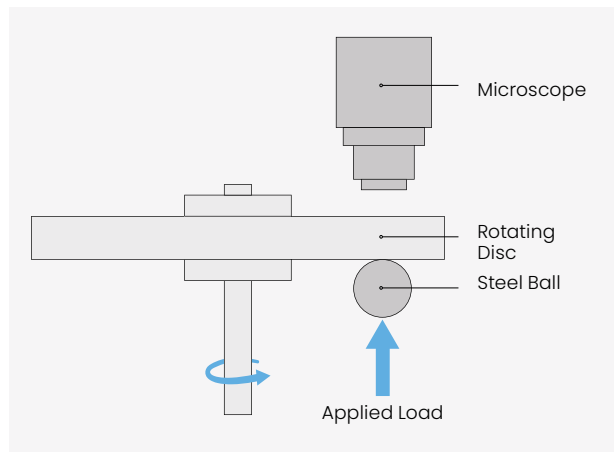

OPTICAL INTERFEROMETRY TECHNIQUE

1. White light is directed through the glass disc and split by the chromium layer into transmitted and reflected beams.
2. The transmitted beam travels through the spacer layer and lubricant film, reflects off the ball, and recombines with the reflected beam at the chromium layer interface.
3. A spectrometer analyses the resulting interferogram to determine film thickness from the optical path difference.

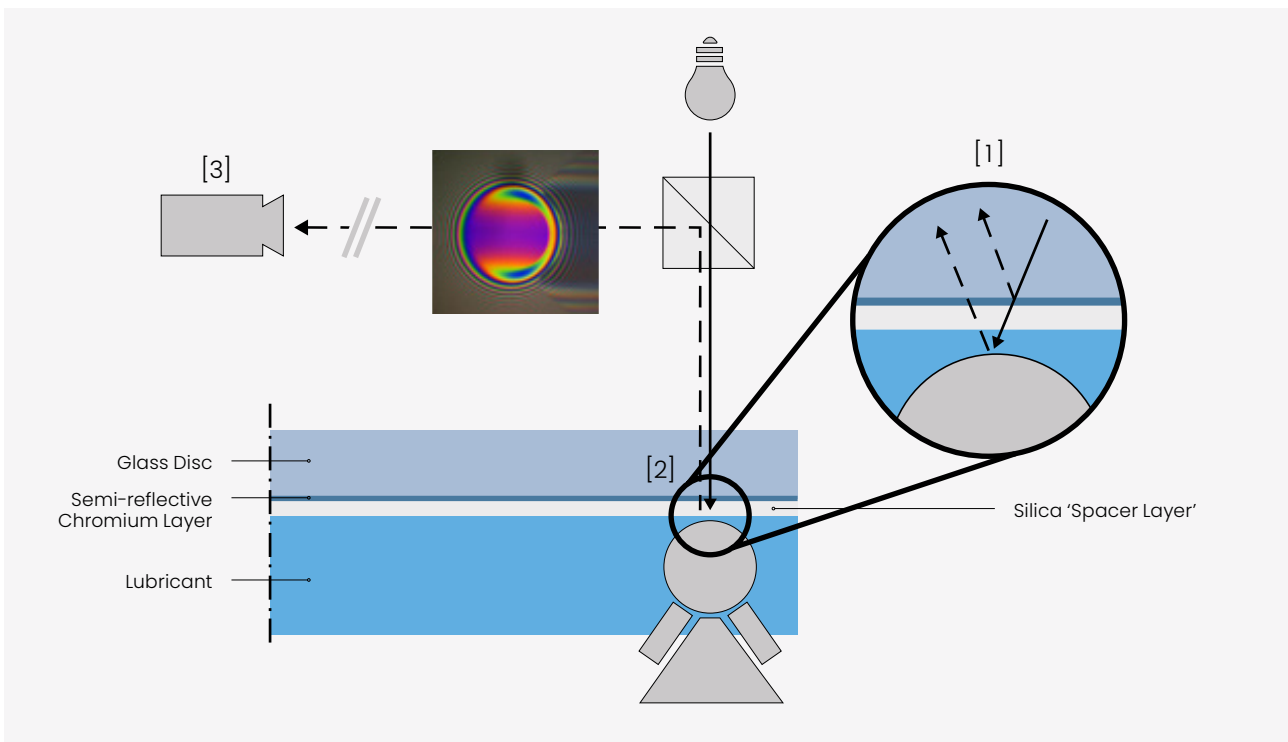

SLIM COMPATIBLE

The Spacer Layer Imaging Method (SLIM) uses a high-resolution colour camera to capture images of the contact area during testing. Its software then correlates the resultant image colours to lubricant film thickness, generating a detailed film thickness map of the entire EHD contact within seconds. This makes SLIM a powerful and unique tool for investigating conditions such as parched or starved lubrication, grease-lubricated contacts, rough surface EHD, and additive-induced tribofilm formation.

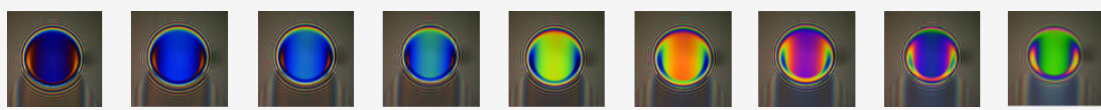

Increasing speed →

EHD-HS



OVERVIEW

A high-speed (up to 20 m/s), fully automated, benchtop instrument, measuring lubricant film thickness down to 1 nm in the elastohydrodynamic (EHD) lubrication regime.

APPLICATIONS

- > Evaluating the film-forming properties of lubricants designed for EV transmissions, turbine bearings and machine tool spindles.
- > Understanding thermal EHL behaviour at higher speeds (> 4 m/s).
- > Simulating high shear operating conditions.
- > Studying additive performance in automotive lubricants, metal working fluids, emulsions, turbine oils and greases.

OPERATING PARAMETERS

Film Thickness	1 to 1000 nm
Load	2 to 50 N
Contact Pressures*	Up to 2.0 GPa
Speed	Up to 20 m/s
Slide / Roll Ratio	0 to +/- 200 %
Temperature Range*	Ambient to 150 °C
Test Sample Volume	120 ml

* Expanded functionality possible with relevant accessories and / or specimens.

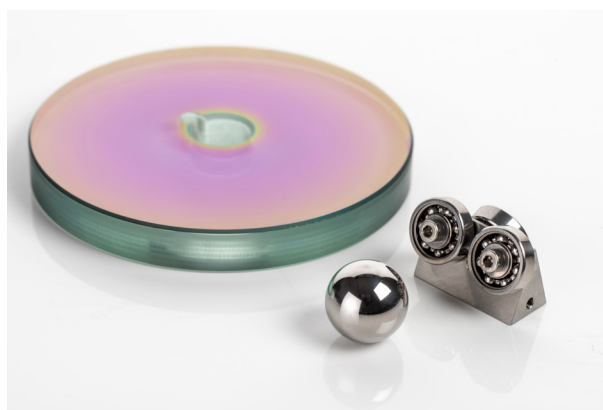
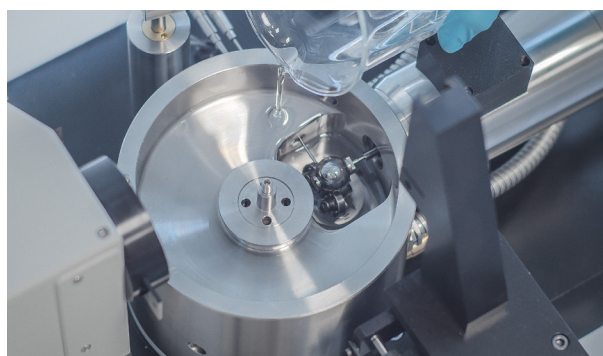

FEATURES & BENEFITS

- > Precision components enable accurate measurements down to 1 nm.
- > Compatible with the optional SLIM system, which includes an upgraded camera, enabling high-quality imaging of the entire EHD contact area - even at the highest operating speeds.
- > Fully automated, easy to calibrate, and has intuitive software.

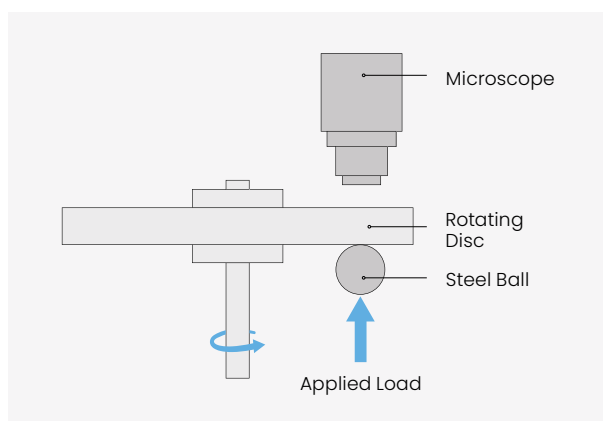

EXAMPLE RESULTS

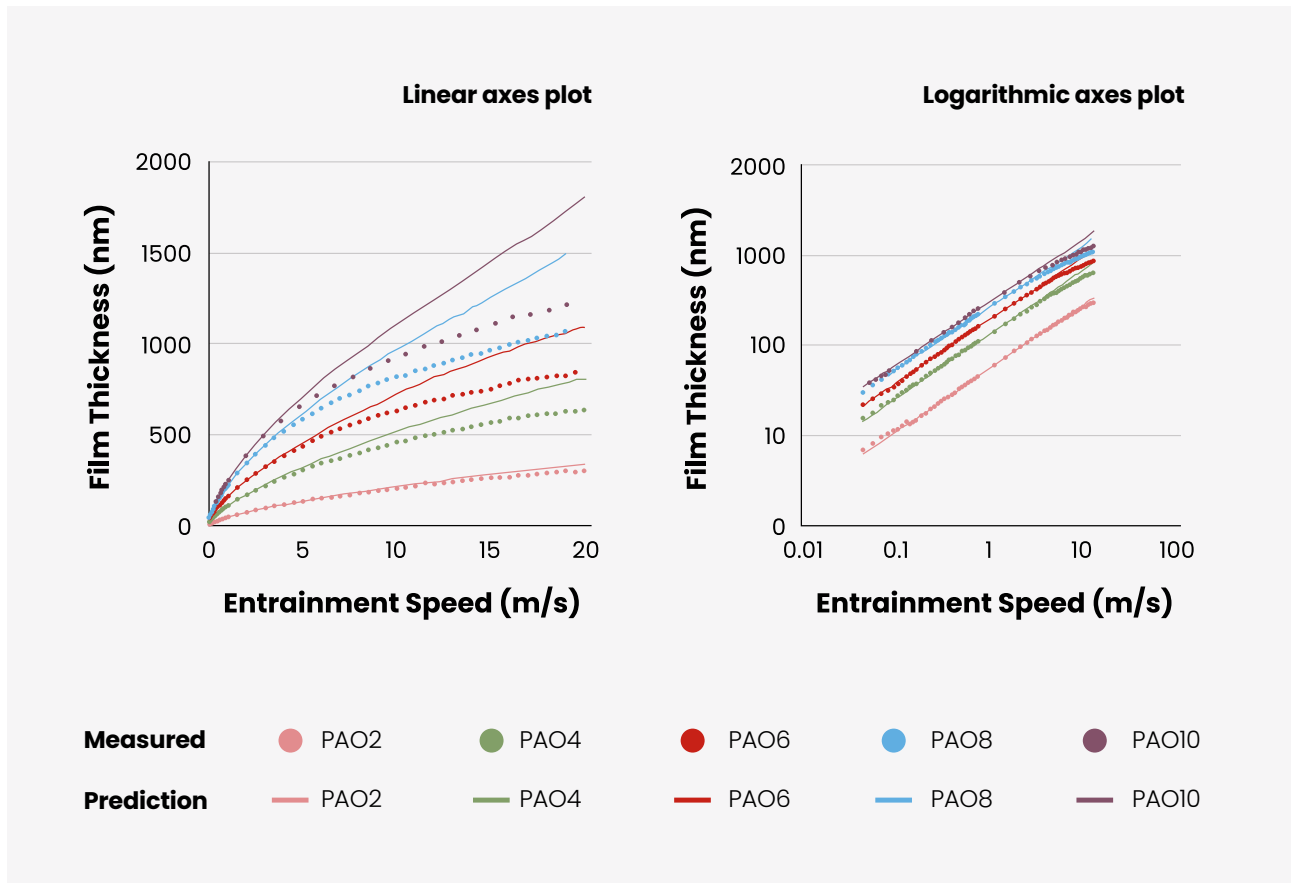

ALPHA VALUE CALCULATION SOFTWARE (AVA)

The pressure-viscosity coefficient is a parameter in several film thickness predictions, which quantifies the piezoviscous response of the lubricant.

Despite its limitations in describing true rheology at high pressure, it can be used to predict film thicknesses across a wide range of contact conditions which agree well with measurements. It is therefore a useful fitting parameter, which can be calculated from a small number of EHD film thickness measurements.

The SAE ARP 6157 standard details a procedure using the EHD or EHD-HS to perform the measurements and complete this calculation.

MPR



OVERVIEW

A triple contact machine for researching rolling contact fatigue and other surface damage mechanisms.

FEATURES & BENEFITS

- > 3 ring on roller geometry keeps surface speeds low, whilst allowing over 1 million contact cycles per hour.
- > A torque sensor and accelerometer on the roller shaft provides continuous friction and vibration data during testing.
- > Temperature controlled test chamber.
- > The only instrument specified in SAE International MPR Micropitting Test Method ARP6991 standard for evaluating the micropitting performance of aviation turbine oil formulations.



RELEVANT DAMAGE MECHANISMS



Micropitting

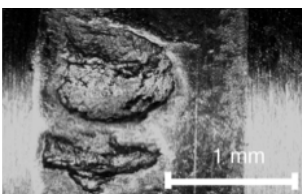

Macropitting



Scuffing

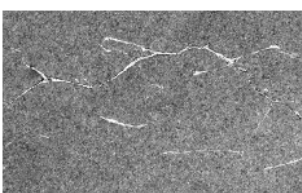

White Etching Cracks

Manieri, F., Stadler, K., Morales-Espejel, G. E., & Kadiric, A. (2019). The origins of white etching cracks and their significance to rolling bearing failures. *International Journal of Fatigue*, 120, 107–133. <https://doi.org/10.1016/j.ijfatigue.2018.10.023>

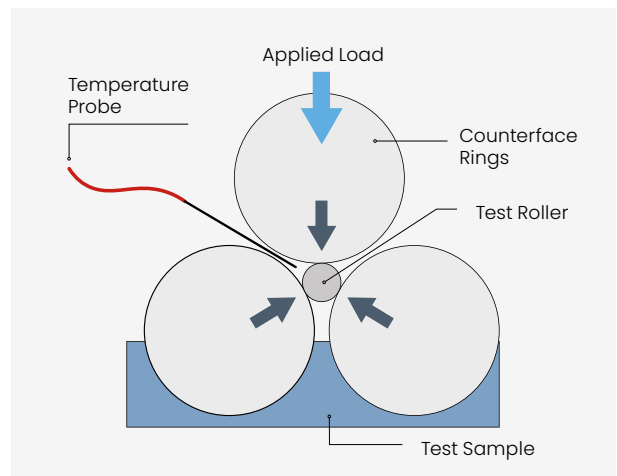

CONTACT OPTIONS

Ring	Cylindrical	Crowned (80 mm)	Crowned (12 mm)	Cylindrical
Roller	Chamfered	Cylindrical	Cylindrical	Crowned (80 mm)
Contact Pressure range (GPa)	0.86 – 3.04	1.03 – 2.36	1.65 – 3.84	1.03 – 2.36

Contact Geometry

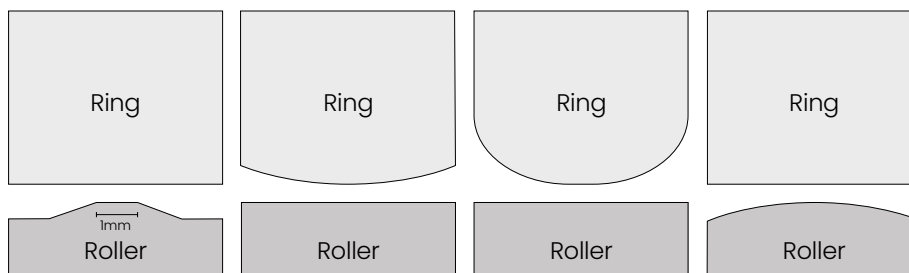

Please contact us to explore custom specimens for your specific research needs.

EXAMPLE RESULTS

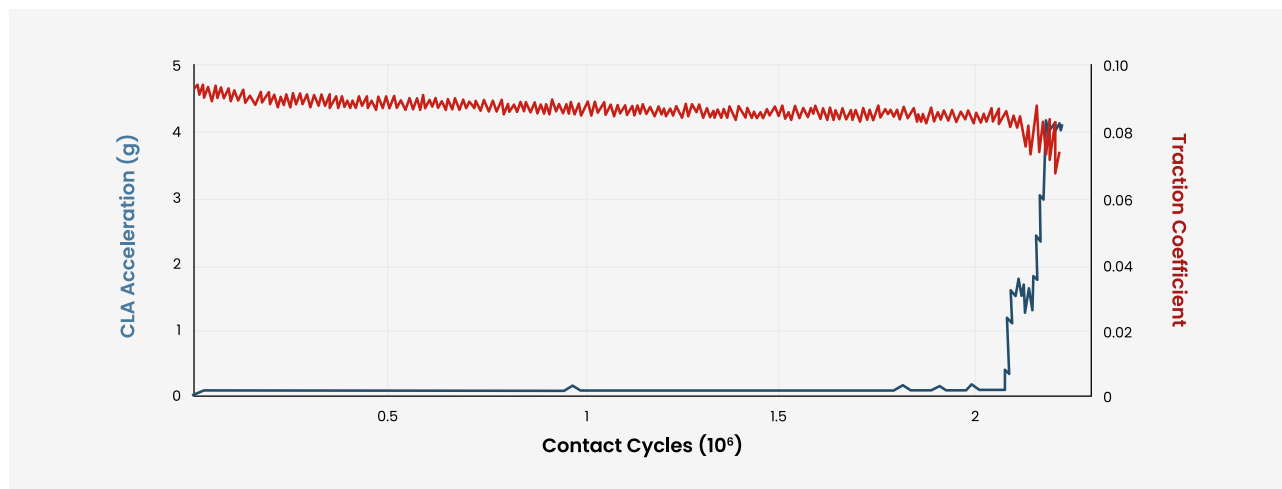

Rapid changes in accelerometer and traction data indicative of pitting damage.

OPERATING PARAMETERS

Load	100 to 1250 N
Speed	Up to +/- 4 m/s
Slide / Roll Ratio	0 to +/- 200 %
Temperature Range	Ambient to 135 °C
Maximum Roller Torque	20 Nm (total of all 3 contacts)
Test Sample Volume	150 ml



MPR-GI



OVERVIEW

An accessory for the MPR, designed to deliver grease to the contact in a controlled, accurate and repeatable way, preventing starvation and allowing for the clear assessment of the fatigue behaviour of greases.



OPERATING PARAMETERS

Temperature Range	Ambient to 90 °C
Maximum Syringe Volume	300 ml
Rate of Injection	0.07 to 20,000 mL / Hr (grease-consistency dependent)
Maximum NLGI Grade	3

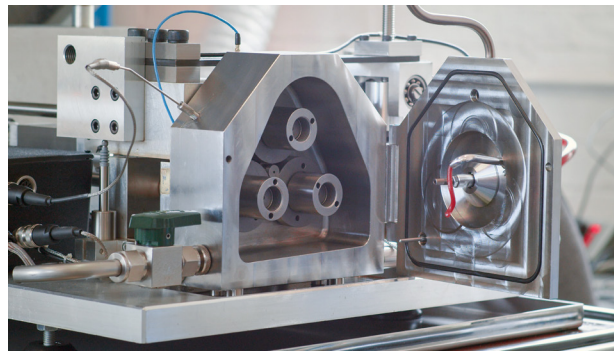

FEATURES & BENEFITS

- > Provided as a kit that can be easily retrofitted to existing MPRs.
- > Test profiles can be automatically constructed to pause when a grease refill is required.
- > Intermittent or continuous grease supply is user-configurable via the MPR-PC software.



EXAMPLE RESULTS

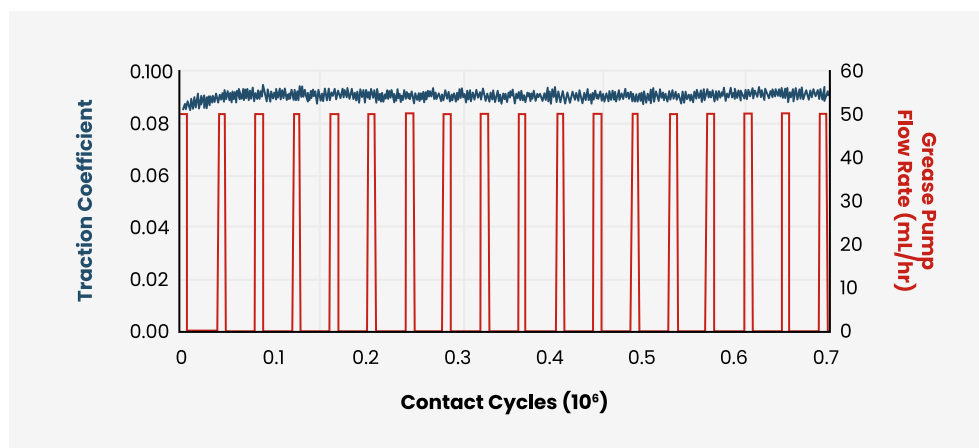

Intermittent injection of a synthetic grease (NLGI Grade 2) to prevent starvation, as indicated by a steady traction response over 700,000 contact cycles.

Specimens



We offer a comprehensive selection of specimens, available in a variety of materials, geometries, surface finishes, coatings, and bulk properties to support a wide range of testing requirements.

For more specialised applications, we are happy to explore custom specimens for your specific research needs.

Contact us to learn more about our specimen range and how they can support your analysis. We are here to help you find the ideal solution for your testing challenges.



PCS APP



The PCS Instruments mobile app makes it easy to calculate Hertzian contact parameters for both our instruments and custom contacts.

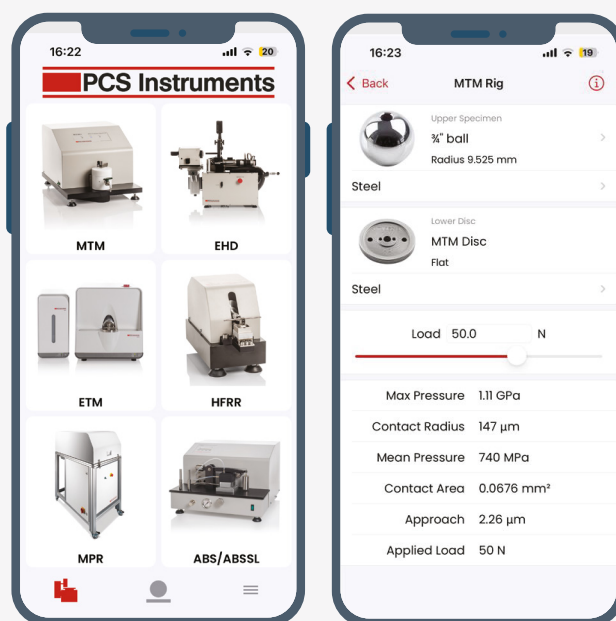



PCS Instruments

info@pcs-instruments.com
+44 (0)20 8600 9920

PCS Instruments Ltd,
78 Stanley Gardens,
London, W3 7SZ
United Kingdom